

TECHNICAL SPECIFICATION

PARAMETER SPECIFICATION

Input Signal	3Ø 3 Wire / 3Ø 4Wire / 1Ø 2Wire
CT Primary	up to 6000A (Programmable)
CT Secondary	5 Amp/1 Amp selectable
PT Primary	100V to 520kV (Programmable)
PT Secondary	100V to 520V (L-L) (Programmable)
PF Avg. & Per Phase	0.100 - 1.000
Frequency (Hz)	45.00 - 60.00 Hz
Load hours	9999.59 Hrs/Min.
No load hours	9999.59 Hrs/Min.
RPM	3600 RPM @ 60 Hz & 2 pole
POWER	
kW Total	0.000 - 9999 MW
kW Per Phase	0.000 - 9999 MW
kVA Total	0.000 - 9999 MVA
kVA Per Phase	0.000 - 9999 MVA
kVAr Total	0.000 - 9999 MVar
kVAr Per Phase	0.000 - 9999 MVar
ENERGY	
kWh Total	000.000 - 99999999 MWh
kVAh Total	000.000 - 99999999 MVAh
kVArh Total	000.000 - 99999999 MVarh

DISPLAY & KEY :

Display	Upper	8 Digit, 7 Seg 0.40", RED LED
	Lower	4 Digit, 3 Line 7 Seg 0.40", RED
Key		PROGRAM, VAF, POWER, ENERGY

DIMENSION :

Size	96 (H) x 96 (W) x 54 (D) mm
Panel Cutout	92 (H) x 92 (W) mm

AUXILIARY SUPPLY :

Supply voltage	100 to 270V AC/DC, 50/60Hz
Power consumption (VA RATING)	Approx 4 VA @ 230V AC MAX

ACCURACY:

Class 0.5 (Standard)

ENVIRONMENT CONDITION:

Operating Temp.	0 °C to 55 °C
Relative Humidity	UP to 95% RH (non-condensing)
Protection Level (AS Per Request)	IP-65 (Front side) As per IS/IEC 60529 : 2001



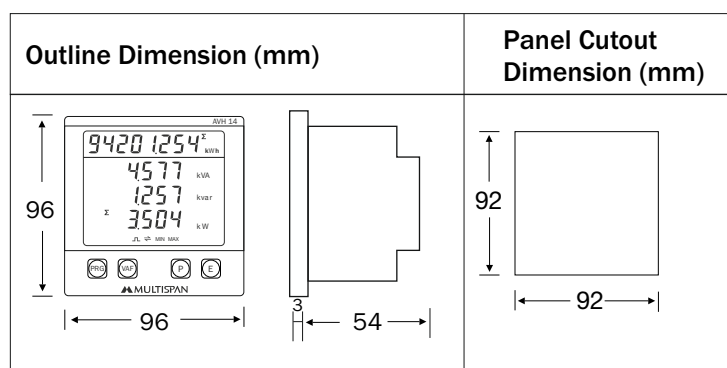



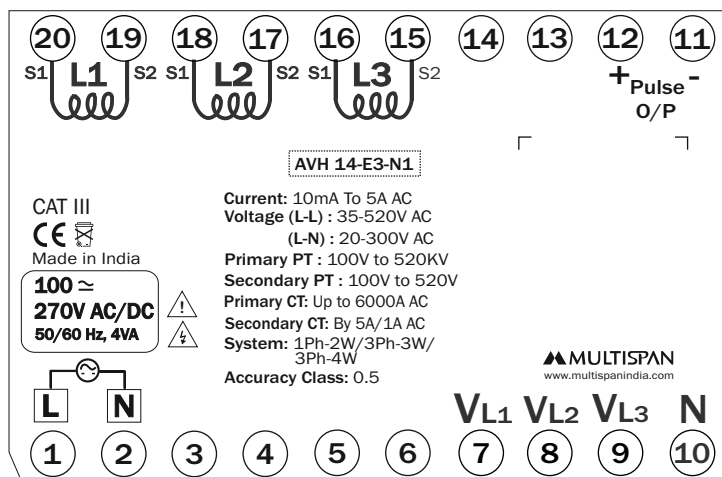

MECHANICAL INSTALLATION



TERMINAL CONNECTION



KEY OPERATION

FUNCTION	PRESS KEY
OPERATOR MODE	
To view different pages	  or 
To Enter into enter setting	 Long Press
PARAMETER SETTING MODE	
To Set Parameter Value	
To Increment parameter value	
To Decrement parameter value	
To Exit from parameter setting	
To Scroll & Hold	 Press 5 Sec

Resolution

PT Ratio x CT Ratio	Pulse/kWh
<15	0.01kWh
<150	0.1kWh
<1500	1kWh
<15000	10kWh
<150000	100kWh
≥150000	1000kWh

INSTALLATION GUIDELINES

1. This equipment, being built-in-type, normally becomes a part of main control panel and in such case the terminals do not remain accessible to the end user after installation and internal wiring.
2. Do not allow pieces of metal, wire clippings, or fine metallic fillings from installation to enter the product or else it may lead to a safety hazard that may in turn endanger life or cause electrical shock to the operator.
3. Circuit breaker or mains switch must be installed between power source and supply terminal to facilitate power 'ON' or 'OFF' function. However this mains switch or circuit breaker must be installed at convenient place normally accessible to the operator.
4. Use and store the instrument within the specified ambient temperature and humidity ranges as mentioned in this manual.

MECHANICAL INSTALLATION GUIDELINES

1. Prepare the panel cutout with proper dimensions as shown above.
2. Fit the unit into the panel with the help of clamp given.
3. The equipment in its installed state must not come in close proximity to any heating source, caustic vapors, oils steam, or other unwanted process byproducts.
4. Use the specified size of crimp terminal (M3.5 screws) to wire the terminal block. Tightening the screws on the terminal block using the tightening torque of the range of 1.2 N.m.
5. Do not connect anything to unused terminals.

MAINTENANCE

1. The equipment should be cleaned regularly to avoid blockage of ventilating parts.
2. Clean the equipment with a clean soft cloth. Do not use isopropyl alcohol or any other cleaning agent.
3. Fusible resistor must not be replaced by operator.



SAFETY PRECAUTION

All safety related codifications, symbols and instructions that appear in this operating manual or on the equipment must be strictly followed to ensure the safety of the operating personnel as well as the instrument.

If all the equipment is not handled in a manner specified by the manufacturer, it might impair the protection provided by the equipment.



Read complete instructions prior to installation and operation of the unit.



WARNING : Risk of electric shock.

WARNING GUIDELINES



WARNING : Risk of electric shock.

1. To prevent the risk of electric shock, power supply to the equipment must be kept OFF while doing the wiring arrangement. Do not touch the terminals while power is being supplied.
2. To reduce electro magnetic interference, use wire with adequate rating and twists of the same of equal size shall be made with shortest connection.
3. Cable used for connection to power source, must have a cross section of 1mm or greater. These wires should have insulations capacity made of at least 1.5kV.
4. A better anti-noise effect can be expected by using standard power supply cable for the instrument.

PARAMETER SETTING

Basic Parameter Setting : Network, CT/PT Selection.

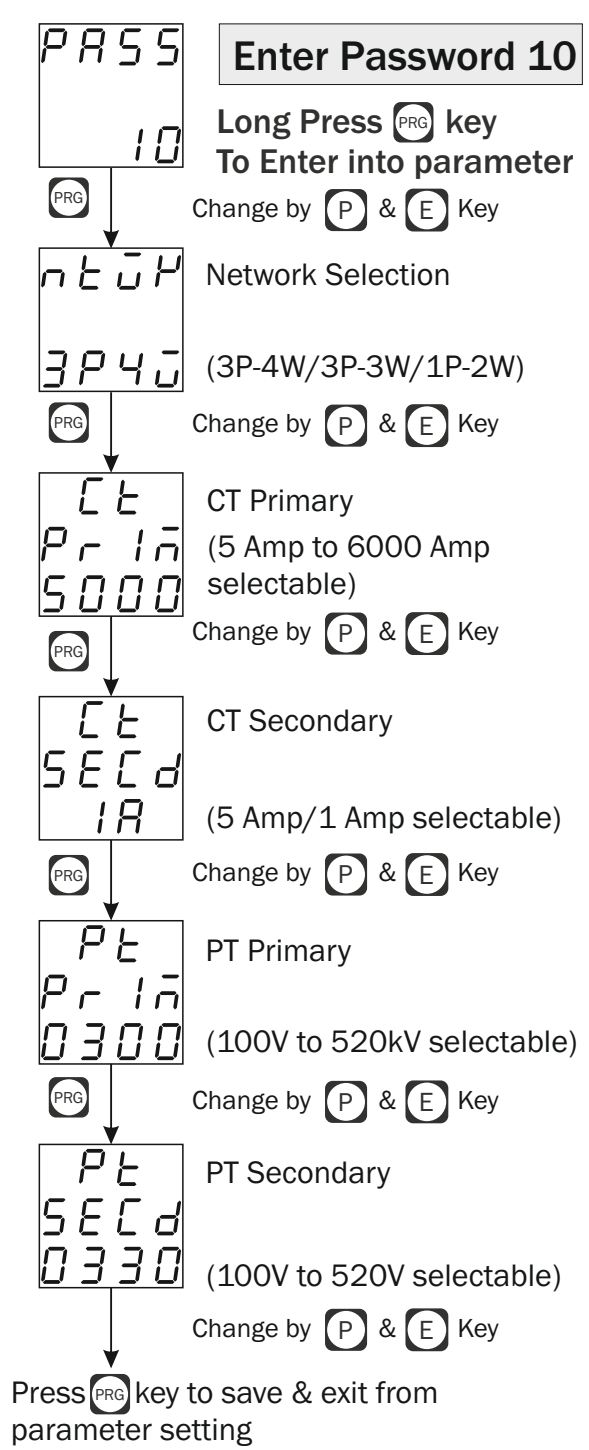

Advance Parameter Setting : Load Hour %, No Load Hour, RPM.

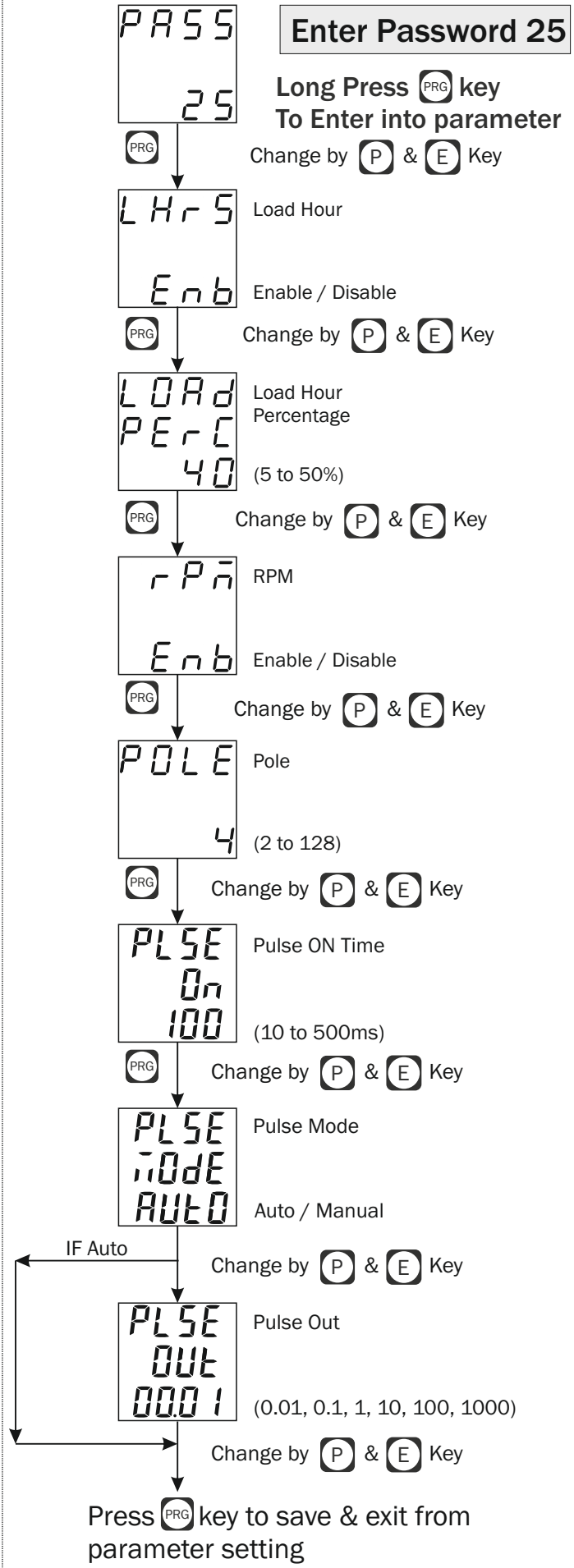

Reset Parameter : kWh, kVAh, kvarh, Load Hour, No Load Hour, Max kW, Max kVA, Max kVAr, Max Voltage, Min Voltage

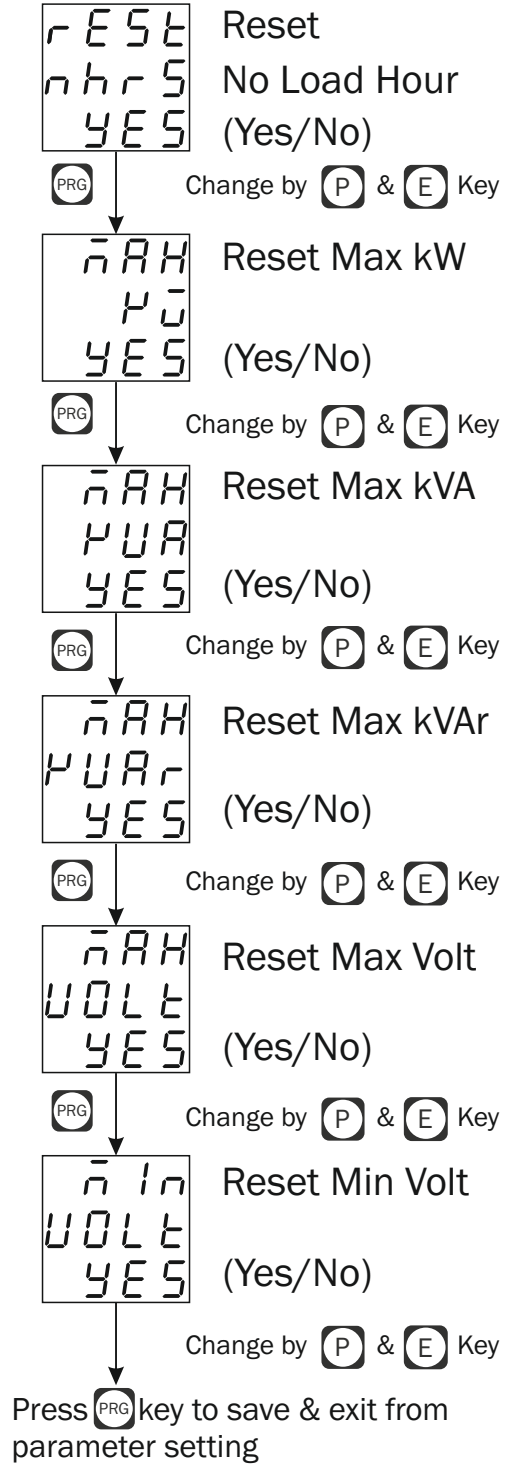
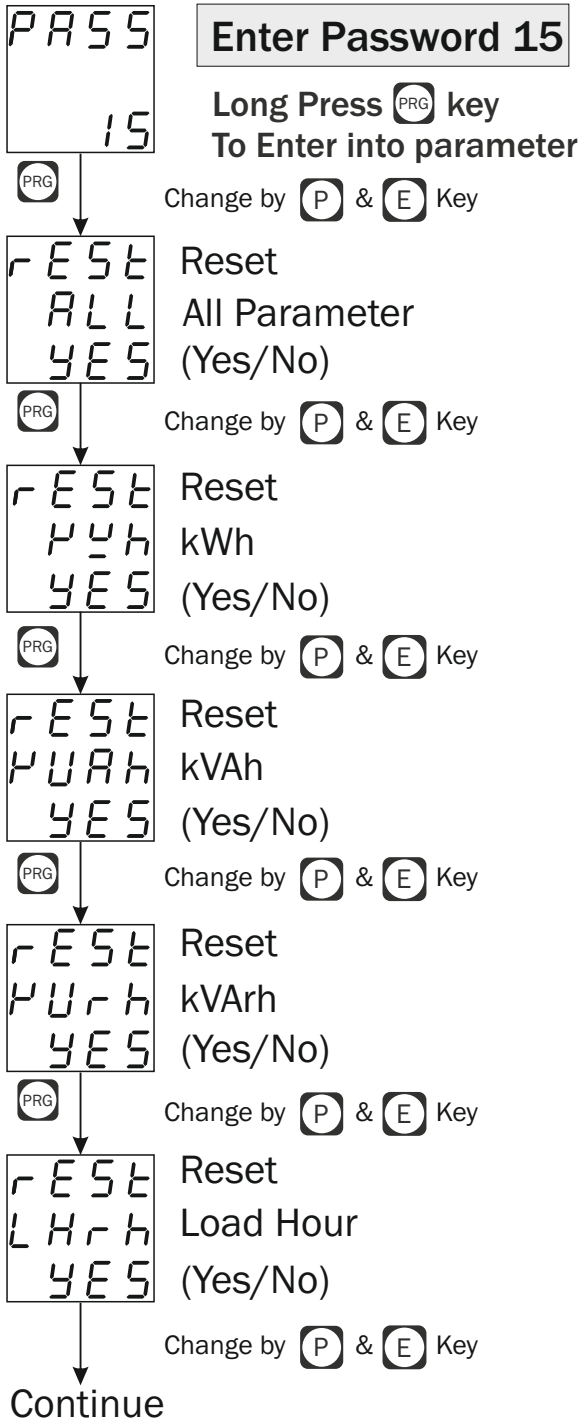

1) Voltage L-N

9420 1254 ^Σ kWh

L₁ 2419 V_{LN}
L₂ 2384
L₃ 2405

	3P-3W	3P-4W
Energy Value		
Display Line 1	-	L1
Display Line 2	-	L2
Display Line 3	-	L3

	3P-3W	3P-4W
Energy Value		
Display Line 1	-	L1
Display Line 2	-	L2
Display Line 3	-	L3

9) Max Voltage L-N

9420 1254 ^Σ kWh

AVG 2435 V_{LN}
MAX

	3P-3W	3P-4W
Energy Value		
Display Line 1	-	-
Display Line 2	-	MAX VALUE
Display Line 3	-	-

	3P-3W	3P-4W
Energy Value		
Display Line 1	-	-
Display Line 2	-	MAX VALUE
Display Line 3	-	-

2) Voltage L-L

9420 1254 ^Σ kWh

L₁₂ 4185 V_{LL}
L₂₃ 4126
L₃₁ 4162

	3P-3W	3P-4W
Energy Value		
Display Line 1	L12	L12
Display Line 2	L23	L23
Display Line 3	L31	L31

	3P-3W	3P-4W
Energy Value		
Display Line 1	L12	L12
Display Line 2	L23	L23
Display Line 3	L31	L31

10) Max Voltage L-L

9420 1254 ^Σ kWh

AVG 4605 V_{LL}
MAX

	3P-3W	3P-4W
Energy Value		
Display Line 1	-	-
Display Line 2	MAX VALUE	MAX VALUE
Display Line 3	-	-

	3P-3W	3P-4W
Energy Value		
Display Line 1	-	-
Display Line 2	MAX VALUE	MAX VALUE
Display Line 3	-	-

3) Current

9420 1254 ^Σ kWh

L₁ 4999 A
L₂ 5001
L₃ 4890

	3P-3W	3P-4W
Energy Value		
Display Line 1	I L1	I L1
Display Line 2	I L2	I L2
Display Line 3	I L3	I L3

	3P-3W	3P-4W
Energy Value		
Display Line 1	I L1	I L1
Display Line 2	I L2	I L2
Display Line 3	I L3	I L3

11) Min Voltage L-N

9420 1254 ^Σ kWh

AVG 2435 V_{LN}
MIN

	3P-3W	3P-4W
Energy Value		
Display Line 1	-	-
Display Line 2	-	MIN VALUE
Display Line 3	-	-

	3P-3W	3P-4W
Energy Value		
Display Line 1	-	-
Display Line 2	-	MIN VALUE
Display Line 3	-	-

12) Min Voltage L-L

9420 1254 ^Σ kWh

AVG 4605 V_{LL}
MIN

	3P-3W	3P-4W
Energy Value		
Display Line 1	-	-
Display Line 2	MIN VALUE	MIN VALUE
Display Line 3	-	-

	3P-3W	3P-4W
Energy Value		
Display Line 1	-	-
Display Line 2	MIN VALUE	MIN VALUE
Display Line 3	-	-

4) PF L1,L2,L3

9420 1254 ^Σ kWh

L₁ 0983
L₂ 0982
L₃ 8981 PF

	3P-3W	3P-4W
Energy Value		
Display Line 1	-	L1 PF
Display Line 2	-	L2 PF
Display Line 3	-	L3 PF

	3P-3W	3P-4W
Energy Value		
Display Line 1	-	L1 PF
Display Line 2	-	L2 PF
Display Line 3	-	L3 PF

5) AVG V(L-N)-A-F

9420 1254 ^Σ kWh

AVG 2402 V_{LN}
4963 A
5005 Hz

	3P-3W	3P-4W
Energy Value		
Display Line 1	-	VLN AVG
Display Line 2	-	I AVG
Display Line 3	-	sys freq

	3P-3W	3P-4W
Energy Value		
Display Line 1	-	VLN AVG
Display Line 2	-	I AVG
Display Line 3	-	sys freq

13) Load Hour

9420 1254 ^Σ kWh

LHr5
213
53

	3P-3W	3P-4W
Energy Value		
Display Line 1	Load Hour	Load Hour
Display Line 2	Value Hour	Value Hour
Display Line 3	Value Min	Value Min

	3P-3W	3P-4W
Energy Value		
Display Line 1	Load Hour	Load Hour
Display Line 2	Value Hour	Value Hour
Display Line 3	Value Min	Value Min

6) AVG V(L-L)-A-F

9420 1254 ^Σ kWh

AVG 4202 V_{LL}
4965 A
5045 Hz

	3P-3W	3P-4W
Energy Value		
Display Line 1	VLL AVG	VLL AVG
Display Line 2	I AVG	I AVG
Display Line 3	sys freq	sys freq

	3P-3W	3P-4W
Energy Value		
Display Line 1	VLL AVG	VLL AVG
Display Line 2	I AVG	I AVG
Display Line 3	sys freq	sys freq

14) No Load Hour

9420 1254 ^Σ kWh

nHr5
150
01

	3P-3W	3P-4W
Energy Value		
Display Line 1	no Load Hour	no Load Hour
Display Line 2	Value Hour	Value Hour
Display Line 3	Value Min	Value Min

	3P-3W	3P-4W
Energy Value		
Display Line 1	no Load Hour	no Load Hour
Display Line 2	Value Hour	Value Hour
Display Line 3	Value Min	Value Min

7) AVG V(L-N)-A-PF

9420 1254 ^Σ kWh

AVG 2402 V_{LN}
4963 A
0983 PF

	3P-3W	3P-4W
Energy Value		
Display Line 1	-	VLN AVG
Display Line 2	-	I AVG
Display Line 3	-	Avg PF

	3P-3W	3P-4W
Energy Value		
Display Line 1	-	VLN AVG
Display Line 2	-	I AVG
Display Line 3	-	Avg PF

15) RPM

9420 1254 ^Σ kWh

rPn
3000

	3P-3W	3P-4W
Energy Value		
Display Line 1	RPM	RPM
Display Line 2	Value	Value
Display Line 3	-	-

	3P-3W	3P-4W
Energy Value		
Display Line 1	RPM	RPM
Display Line 2	Value	Value
Display Line 3	-	-

8) AVG V(L-L)-A-PF

9420 1254 ^Σ kWh

AVG 4202 V_{LL}
4963 A
0983 PF

	3P-3W	3P-4W
Energy Value		
Display Line 1	VLL AVG	VLL AVG
Display Line 2	I AVG	I AVG
Display Line 3	Avg PF	Avg PF

	3P-3W	3P-4W
Energy Value		
Display Line 1	VLL AVG	VLL AVG
Display Line 2	I AVG	I AVG
Display Line 3	Avg PF	Avg PF

1) kW PER PHASE

9420 1254 ^Σ kWh

L₁ 1184
L₂ 1168
L₃ 1152 kW

	3P-3W	3P-4W
Energy Value		
Display Line 1	-	L1 KW
Display Line 2	-	L2 KW
Display Line 3	-	L3 KW

	3P-3W	3P-4W
Energy Value		
Display Line 1	-	L1 KW
Display Line 2	-	L2 KW
Display Line 3	-	L3 KW

2) kVA PER PHASE

9420 1254 ^Σ kWh

L₁ 1209 kVA
L₂ 1192
L₃ 1176

	3P-3W	3P-4W
Energy Value		
Display Line 1	-	L1 KVA
Display Line 2	-	L2 KVA
Display Line 3	-	L3 KVA

	3P-3W	3P-4W
Energy Value		
Display Line 1	-	L1 KVA
Display Line 2	-	L2 KVA
Display Line 3	-	L3 KVA

3) kvar PER PHASE

9420 1254 ^Σ kWh

L₁ 0296
L₂ 0239
L₃ 0236 kvar

	3P-3W	3P-4W
Energy Value		
Display Line 1	-	L1 KVar
Display Line 2	-	L2 KVar
Display Line 3	-	L3 KVar

	3P-3W	3P-4W
Energy Value		
Display Line 1	-	L1 KVar
Display Line 2	-	L2 KVar
Display Line 3	-	L3 KVar

4) Total kW,kVA,kvar

9420 1254 ^Σ kWh

Σ 3577 kVA
0257 kvar
3504 kW

	3P-3W	3P-4W
Energy Value		
Display Line 1	Total kVA	Total kVA
Display Line 2	Total kVar	Total kVar
Display Line 3	Total kW	Total kW

	3P-3W	3P-4W
Energy Value		
Display Line 1	Total kVA	Total kVA
Display Line 2	Total kVar	Total kVar
Display Line 3	Total kW	Total kW

5) Max kW,kVA,kvar

9420 1254 ^Σ kWh

Σ 4577 kVA
1257 kvar
3504 kW
MAX

	3P-3W	3P-4W
Energy Value		
Display Line 1	Total kVA	Total kVA
Display Line 2	Total kVar	Total kVar
Display Line 3	Total kW	Total kW

	3P-3W	3P-4W
Energy Value		
Display Line 1	Total kVA	Total kVA
Display Line 2	Total kVar	Total kVar
Display Line 3	Total kW	Total kW

1) Total kWh

9420 1254 ^Σ kWh

Σ 3577 kVA
0257 kvar
3504 kW

	3P-3W	3P-4W
kWh Value		
Display Line 1	Total kVA	Total kVA
Display Line 2	Total kVar	Total kVar
Display Line 3	Total kW	Total kW

	3P-3W	3P-4W
kWh Value		
Display Line 1	Total kVA	Total kVA
Display Line 2	Total kVar	Total kVar
Display Line 3	Total kW	Total kW

2) Total kVAh

9528 1254 ^Σ kWh

Σ 3577 kVA
0257 kvar
3504 kW

	3P-3W	3P-4W
kVAh Value		
Display Line 1	Total kVA	Total kVA
Display Line 2	Total kVar	Total kVar
Display Line 3	Total kW	Total kW

	3P-3W	3P-4W
kVAh Value		
Display Line 1	Total kVA	Total kVA
Display Line 2	Total kVar	Total kVar
Display Line 3	Total kW	Total kW

3) Total kvarh

1938 1624 ^Σ kWh

Σ 3577 kVA
0257 kvar
3504 kW

	3P-3W	3P-4W
kVarh Value		
Display Line 1	Total kVA	Total kVA
Display Line 2	Total kVar	Total kVar
Display Line 3	Total kW	Total kW

	3P-3W	3P-4W
kVarh Value		
Display Line 1	Total kVA	Total kVA
Display Line 2	Total kVar	Total kVar
Display Line 3	Total kW	Total kW